

Product Brochure  
Lift King LK-07 High Rise Scissor Lift - Surface Mount



Overview

Both the commercial work shop and home garage will find the Lift King LK-07 the perfect tool for general auto service and tyre work as it gives uninterrupted access to all parts of the vehicle at a comfortable full standing working height.

The LK-07 has been constructed to a very high standard using superior mechanical and electrical components. It has passed strict EC type examinations and Australian Certification, so it's built tough to last!

Lift King LK-07 is a full rise scissor lift with a low profile and high lift capacity.

- 3000kg lift capacity
- Full 2000mm lift height
- Low 115mm minimum height clearance
- Electric over hydraulic operating system, NO AIR NEEDED!



Product Brochure  
Lift King LK-07 High Rise Scissor Lift - Surface Mount



Features

- International CE Certified and Australian Certified for Work Cover
- Surface mounted design for easy drive on entry
- Hydraulic safety locks automatically engage when lifting
- Electronic release safety lock release system, not mechanical. NO AIR NEEDED!
- Heavy duty dual hydraulic cylinders to each platform ensures perfectly synchronized lifting between ramps
- Hydraulic cylinders are covered for protection
- Hydraulic equalization for easy uninterrupted access between ramps
- Electro-hydraulic power system with either 240V single-phase or 415V three- phase power box
- Extendable drive-on platforms can be fixed flat to platforms for longer wheel base vehicles
- High 2000mm lift and low 115mm minimum height
- Automatic safety stop device at 300mm with 2 lowering buttons needed to be pushed to continue lowering from 300mm with audible safety alarm
- Optional extra Leveling Bar Kit available for added stability with wider vehicles
- Full set of rubber lift pads included
- Non-slip checker plate finish
- Lubricating bushes and nipples
- Warranty: 5-Year Structural & 1-Year Parts



Hero Hoists QLD  
Address: 1/56 Commerce Circuit, Yatala QLD 4207  
M: 0432 761 705 | P: 07 3272 2952 | F: 07 5609 6031 | E: grant@herohoistsqld.com.au

Product Brochure  
Lift King LK-07 High Rise Scissor Lift - Surface Mount



Specifications

- Lifting capacity: 3.0T
- Lift height: 2000mm
- Minimum height: 115mm
- Platform length: 1608mm
- Platform length with drive-on ramps extended: 2028mm
- Total width: 2030mm
- Width between inside of platforms: 750mm
- Platform width: 600mm
- Lifting time: 40 seconds
- Power Supply: 3HP 240V/415V
- Overall Weight : 866kg

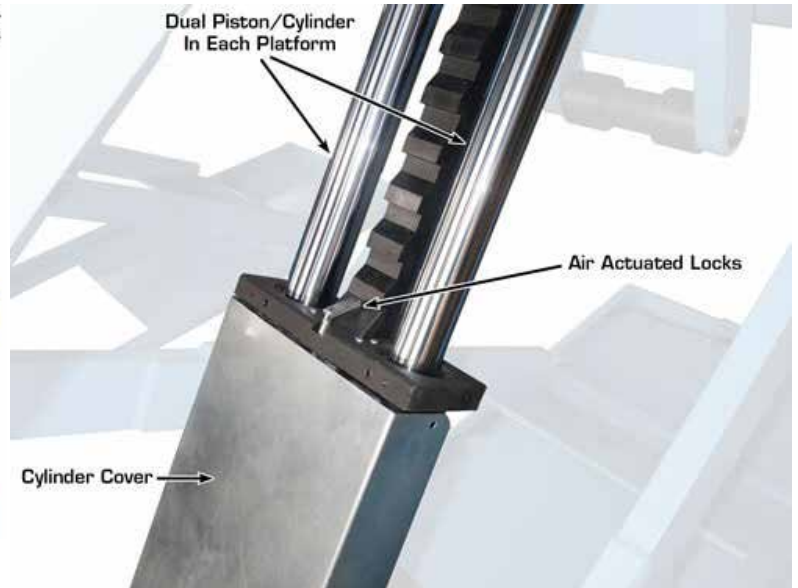
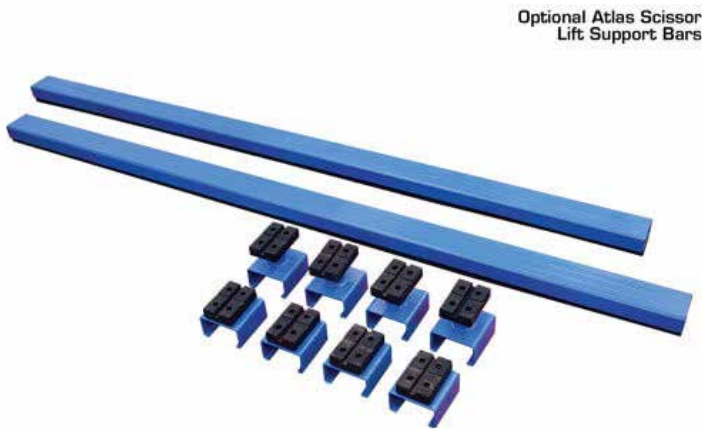

**OPTIONAL EQUIPMENT**



SLP-9K Control Panel And 220V Single Phase Power Unit



Hero Hoists QLD

Address: 1/56 Commerce Circuit, Yatala QLD 4207

M: 0432 761 705 | P: 07 3272 2952 | F: 07 5609 6031 | E: grant@herohoistsqld.com.au

Product Brochure  
Lift King LK-07 High Rise Scissor Lift - Surface Mount

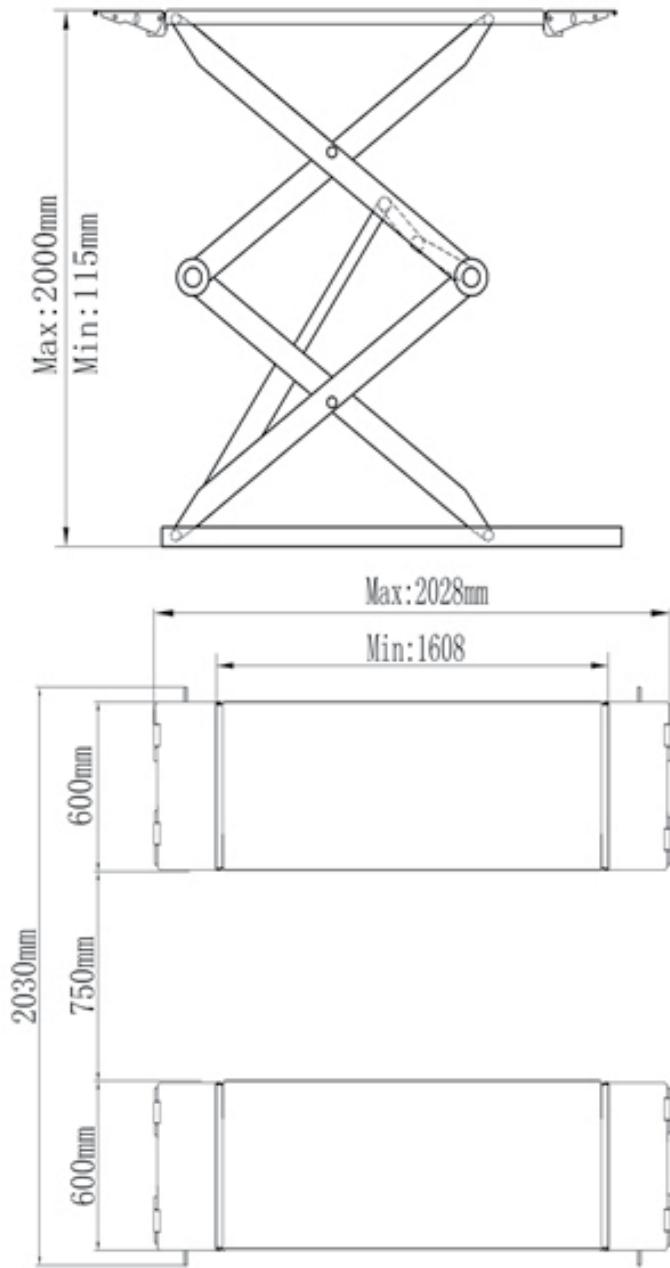

**Specification**

Model	capacity	lifting time	lifting height	Runway width	overall length	overall width	width between runways	gross weight	motor
LK-07	3.0 T	40 S	2000mm	600mm	2028mm	2030mm	750mm	866kg	3.0HP

Hero Hoists QLD  
Address: 1/56 Commerce Circuit, Yatala QLD 4207  
M: 0432 761 705 | P: 07 3272 2952 | F: 07 5609 6031 | E: grant@herohoistsqld.com.au