

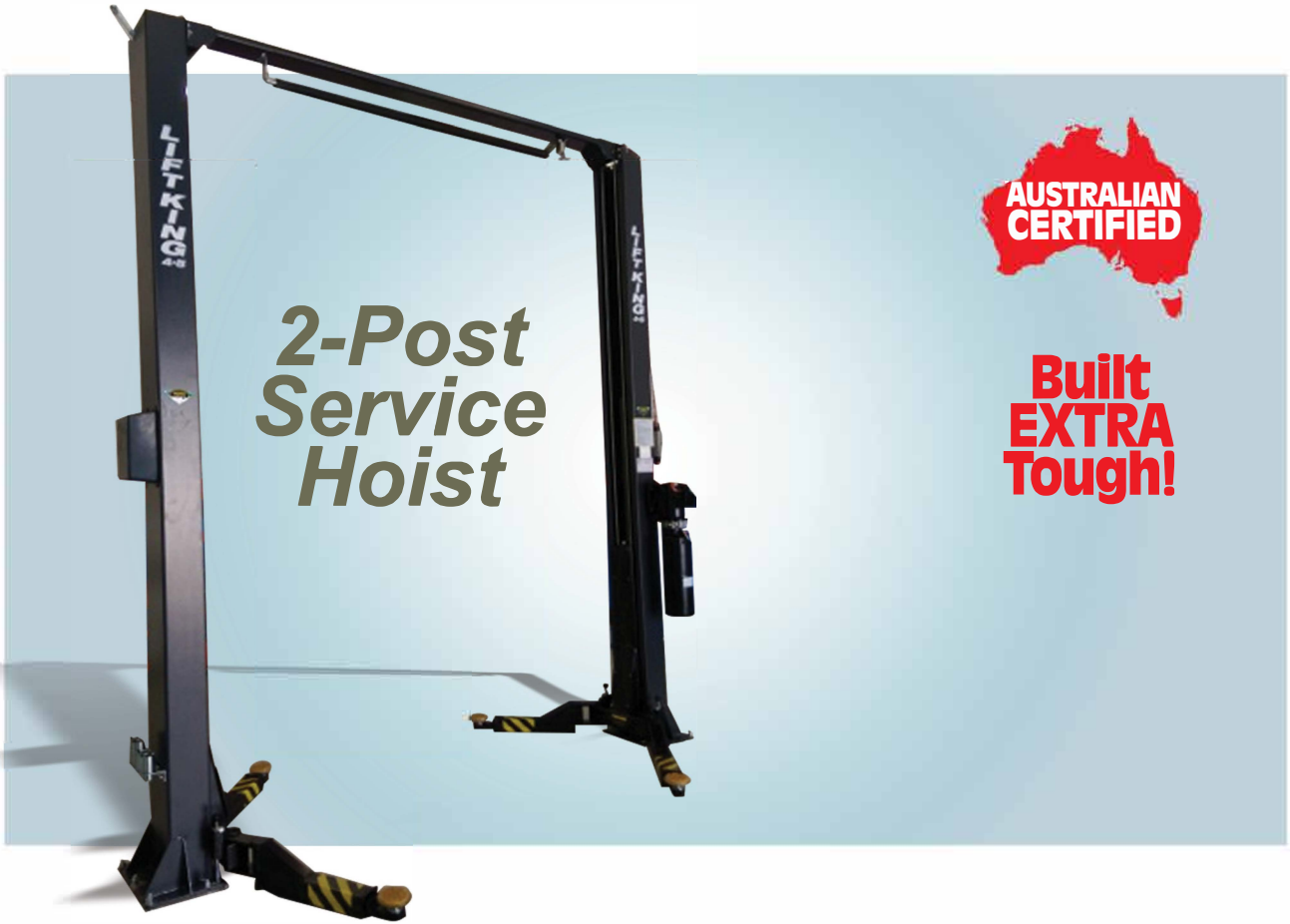

Lift King 2-Post

4.5T Clear Floor



- 4.5T Lifting Capacity
- Australian Certified For Commercial Workshops
- Lifetime Structural Warranty (Domestic Use),
- 5 Year Structural Warranty (Commercial Use)
- 1 Year Parts Warranty
- 240V Single Phase or 415V Three Phase Option
- Single Point Manual Safety Lock Release System
- 3-Stage Asymmetric Arms, Symmetric One Piece Posts
- 100mm 4WD Pad Extensions Included
- High Quality Leak Resistant Hydraulic Ram in Each Post
- Longer Rams & Taller Posts for Extra High Lift and Maximum Clearance. And No Chains!
- DIY Install, Delivery & Installation OR Delivery Anywhere in Australia.
- FREE Pickup from our Salisbury Warehouse
- All Spare Parts Readily Available

Specifications

Model	Lifting Capacity	Post Height	Post Width	Inside Post Width	Drive Through	Max. Lift Height	Top Lock	Max. Roof Height Needed	Min. Pad Height	Clearance Under Limit Bar	Lift Time	Weight
QJ-Y-2-45A	4.5T	3900mm	3420mm	2800mm	2500mm	2080mm	1910mm	4100mm	100mm	3795mm	45 Sec	700kg

Hero Hoists Qld, 1/56 Commerce Circuit, Yatala QLD 4207
 Ph: 0432 761 705 Email: grant@herohoistsqld.com.au



Lift King 4.5T Clear Floor Hoist

3366

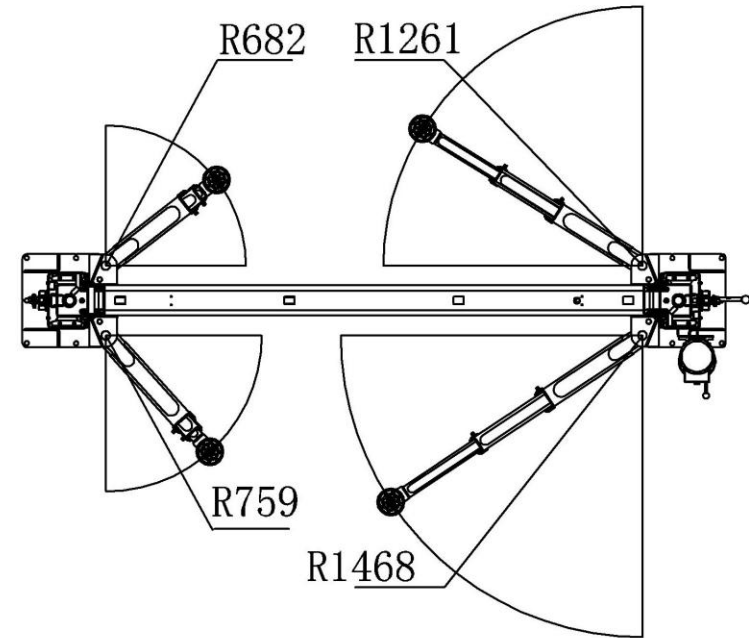
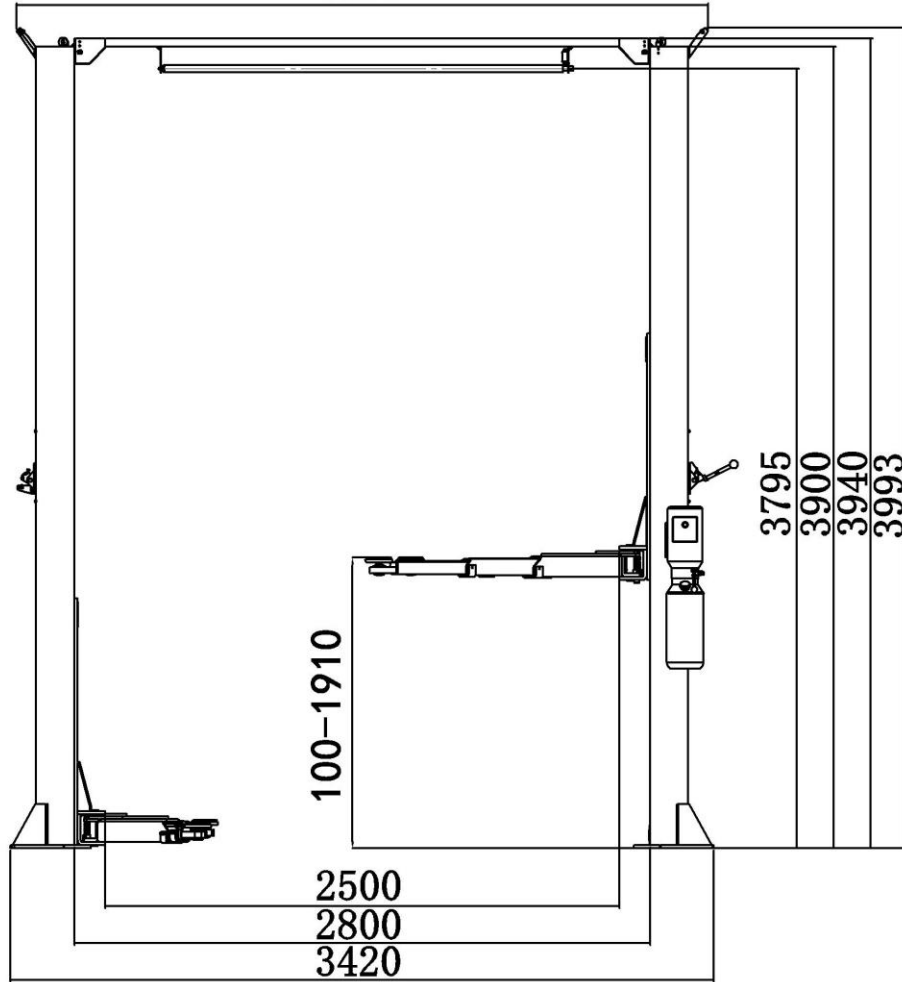



LIFT KING 4.5T 2-POST HOIST SPECIFICATIONS

Lifting Capacity	4.5TON
Lifting Time	45 SEC
Post Height/Installation Height	3990MM
Total Hoist Height with Rams fully extended through top of posts	4200MM
Hoist Width to outside of posts foot flanges	3420MM
Inside of posts width/clearance	2800MM
Drive Through Clearance	2500MM
Height Clearance Under Top Safety Limit Bar	3795MM
Lifting Pad Height at Top Safety Lock (pad screwed down)	1980mm
Lifting Pad Height at Top safety Lock (pad screwed all the way up)	2060mm
Lifting Pad Height when arms extended to maximum above top safety lock	2180mm
Maximum Head Clearance Height Under the Arms	2030mm
Minimum Pad Height at floor level	100mm
<i>Add 100mm to above pad heights when 100mm 4WD adapters are inserted</i>	