

# Lift King 7/2-Post Workshop Hoist

Hero Hoists introduces the lift you've been waiting for...

**Commercial-Grade Quality - at NO Extra Cost!**

Made even better for 2015...  
with our exclusive **LIFETIME**  
Structural Warranty... \*

**COMMERCIAL TOUGH**  
Residential Simple



**Lift King**  
**7/2-Post**  
**(3.50T)**

\* Private Use.

Colours are representational only. Call for details...

## FEATURES

- 8,000 Lb. Capacity
- Dual hydraulic cylinders, designed and made to ANSI standard, high quality NOK seals
- 5/16" aircraft quality cable is used for synchronization
- Self-lubricating UHMW Polyethylene sliders and bronze bush
- Convenient Single-Point Lock Release
- **Supersymmetric** arms design with three-stages front arms and two-stages rear arms
- Stackable rubber pad with 1.5" and 3" extension adaptors \*
- Automatic arms restraints
- Hydraulic power unit

\* 5" Adaptor included at no extra cost...

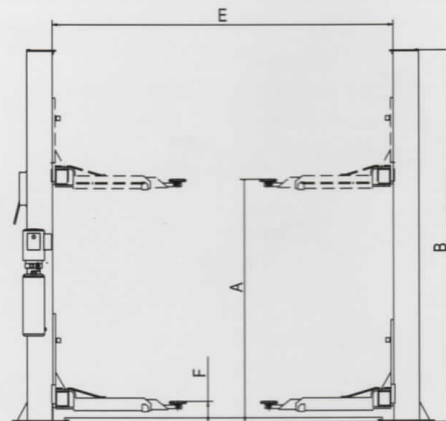
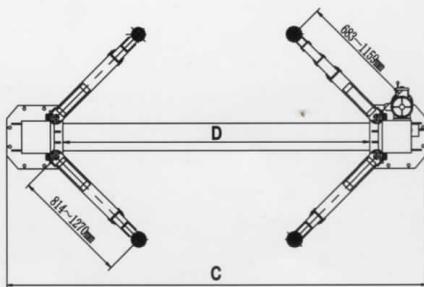

Call us for current pricing...

0432 761 705

07 3272 2952

**THE NEW COMMERCIAL GRADE**  
**2-POST SERVICE LIFT FOR 2015**



**Lift King 3.5T 2-Post Floor Mount Hoist**

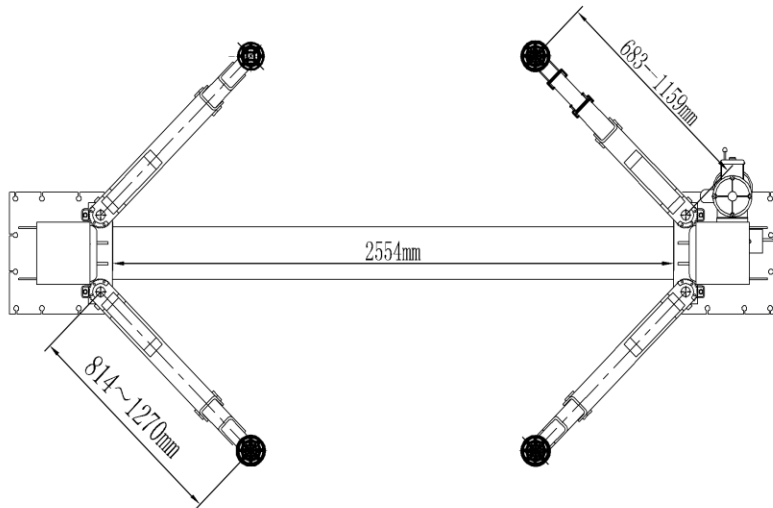
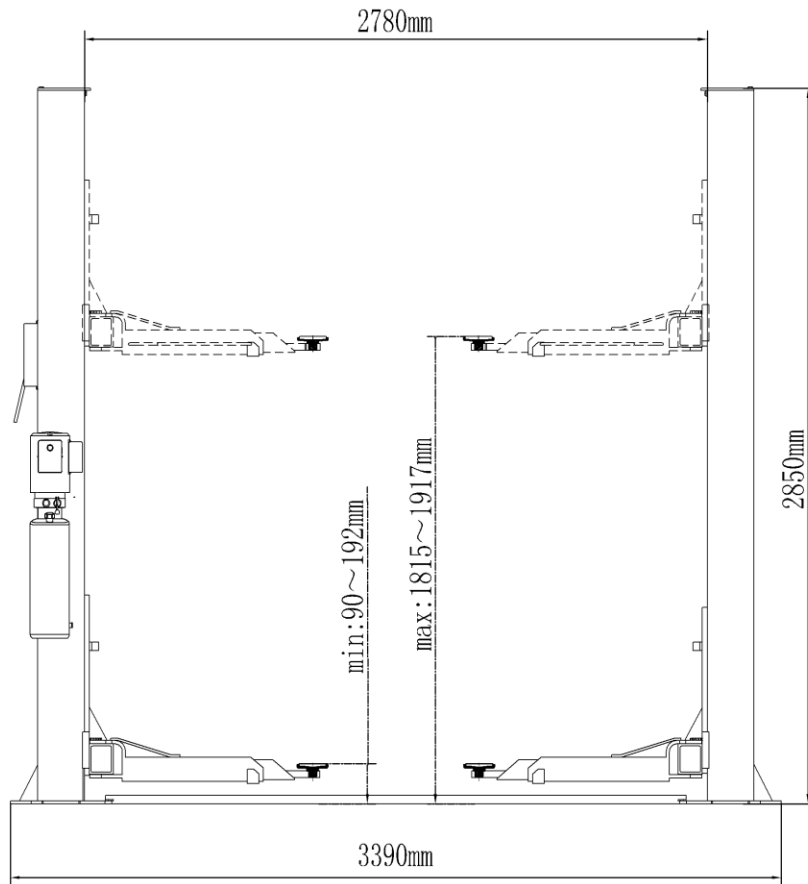

Model	Style	Lifting Capacity	Lifting Time	Lifting Height	Overall Height	Overall Width	Width Between columns	Drive Thru Clearance	Min. Pad Height	G.W.	Motor
208	Base plate	3.5 T	45 S	1815~1917mm	2850mm	3390mm	2780mm	2554mm	90mm	554kg	2.0/3.0 HP

# Lift King 9/2-Post 'Pro-Line' Workshop Hoist

**NEW for 2015 - Australian Certified - EXTRA TOUGH...**

**Commercial-Grade Quality - at NO Extra Cost!**

**The ONLY lifts with an exclusive LIFETIME Structural Warranty\***



## FEATURES

- 9,000 Lb. Capacity
- Dual hydraulic chain-driven cylinders manufactured to ANSI standards
- Aircraft quality cable is used for synchronization
- Self-lubricating UHMW Polyethylene sliders and bronze bushings
- Single-point safety release allows technician to easily release both column locks from one column
- Automatic arm restraints
- Stackable rubber pads



- Dual Locks in each column + Single-Point Release is more convenient and quicker than manually releasing the locks from both posts...
- Throttle-Control inside cylinder. (in case of hydraulic system or hose failure, the arms will not descend rapidly...)



- Super Symmetric Arms allow you to load vehicles in an asymmetric or symmetric configuration.
- Automatic Arm Restraints.
- Rubber Door Guards
- Self-Lubricating Sliders



- Stackable Rubber Pads with 3 sets of extensions...



- Optional Base Plate Extension Kit allows you to safely install the lift into less-than-perfect floors...

**COMMERCIAL TOUGH**  
Residential Simple

Call us for current pricing...

0432 761 705

07 3272 2952

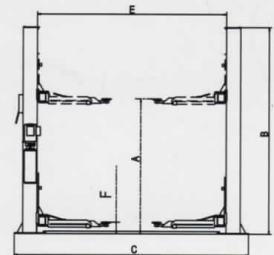
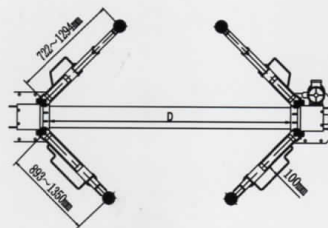

## SPECIFICATIONS

Model	Style	Lifting Capacity	Lifting Time	A	B	C	D	E	F	Gross Weight	Motor
				Lifting Height	Overall Height	Overall Width	Drive-Thru Clearance	Width Between Columns	Minimum Pad Height		
7/2	Floorplate	3.5T	45 Seconds	1815-1930mm	2850mm	3390mm	2554mm	2780mm	90mm	590kg	2.0/3.0HP
9/2 Pro	Floorplate	4.0 T	49 Seconds	1940-2210mm	2841mm	3460mm	2623mm	2850mm	90mm	675kg	2.0/3.0HP

\* Private Use.

• Optional 2-Year Extended

Motor & Parts Warranty available. Call for details...

• Colours are representational only.

**THE NEW COMMERCIAL GRADE  
2-POST SERVICE LIFT FOR 2015**



## Lift King 4.0T 2-Post Floor Mount Hoist

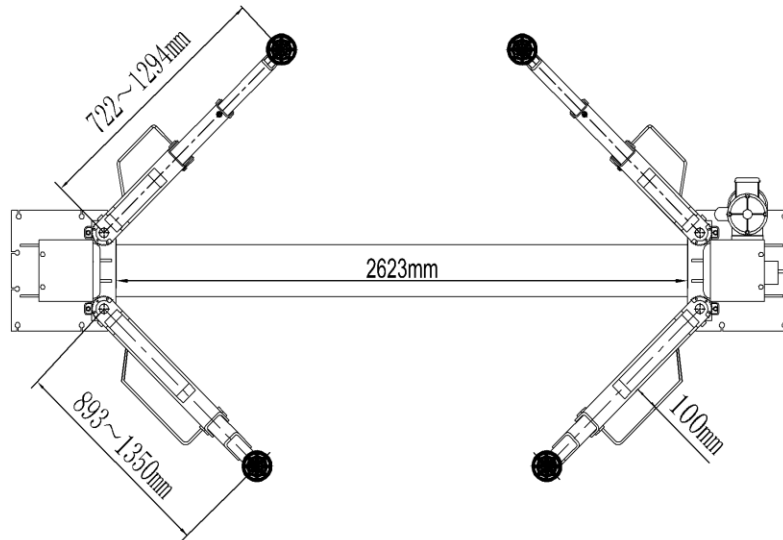
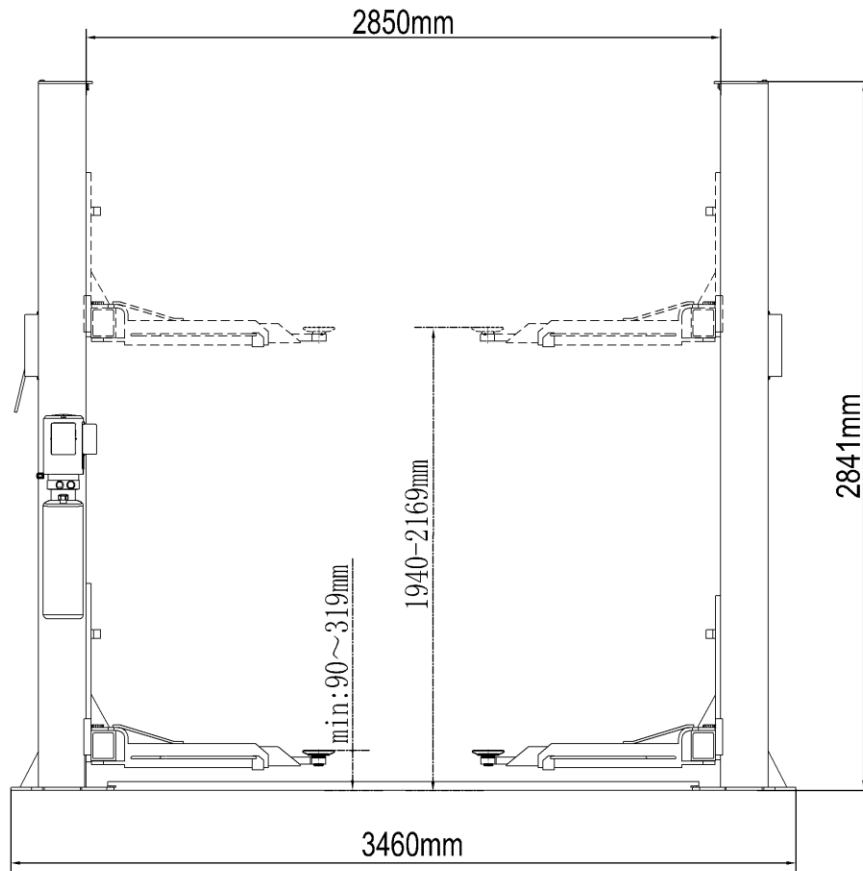

Model	Style	Lifting Capacity	Lifting Time	Lifting Height	Overall Height	Overall Width	Width Between columns	Drive Thru Clearance	Min. Pad Height	G.W.	Motor
209X	Base Plate	4.0 T	49 S	1940~2169mm	2841mm	3460mm	2850mm	2623mm	90mm	675kg	2.0/3.0 HP