

Product Brochure  
Lift King LK-125 Portable Single Post Hoist



## Overview

The Lift King LK-125 Portable Single Post Hoist is extremely versatile as it can perform all the vehicle servicing jobs of a standard 2-post hoist but with the added benefits of being easily and quickly moved by one operator and it only takes up a small amount of work shop space.

The incorporated trolley jack means that when your workshop is full, you can move the hoist outside to work on your vehicles. And when you're finished with it, you can easily roll it away to a corner for storage.

It's extra heavy duty construction and sturdy base make it a very safe and stable hoist to use, and it's backed by Australian Certification design standards.

- Roll it anywhere inside or outside the work shop
  - Space saving single post design
- EXTR HIGH 2.7T lift capacity & 1920mm lift height
- Built TOUGH 865kg net weight, that's 170kg heavier than our competitors, safer & stronger!
  - Australian Certified for commercial work shops



*Product Brochure*  
*Lift King LK-125 Portable Single Post Hoist*



**Features**

- Portable freestanding design with strong nylon wheels
- Space saving single post design
- Electro-hydraulic control Powerpack, 1 hand push button operation
- 240V single-phase or 415V three-phase power option
- Simple and reliable single point cable pull safety lock release
- Mechanical safety locks device prevents accidental lowering
- Single hydraulic cylinder with extra heavy duty leaf chain
- Fully adjustable front and rear arms can extend and swivel to suit any vehicles lifting points
- Over load safety valve, lowering speed control valve and hydraulic circuit break valve incorporated for added safety
- Adjustable screw-up pads and 8-piece drop-in adaptor set for 4WD
- High quality export standard aluminum motor shell power unit and solenoid valve
- Foot protectors on all arms and inside post chain cover
- Specially designed transport frame to prevent shipping damage



Product Brochure  
Lift King LK-125 Portable Single Post Hoist



---

**Specifications**

- Lifting capacity: 2.7T
- Lifting height: 1920mm
- Minimum height: 125mm
- Post height: 2610mm
- Platform base length: 1750mm
- Hoist width/arms extended: 1340mm/1830mm
- Lifting time: 55 seconds
- Net weight: 865kg
- Structural Warranty: 5-year
- Parts Warranty: 1-Year





Product Brochure  
Lift King LK-125 Portable Single Post Hoist

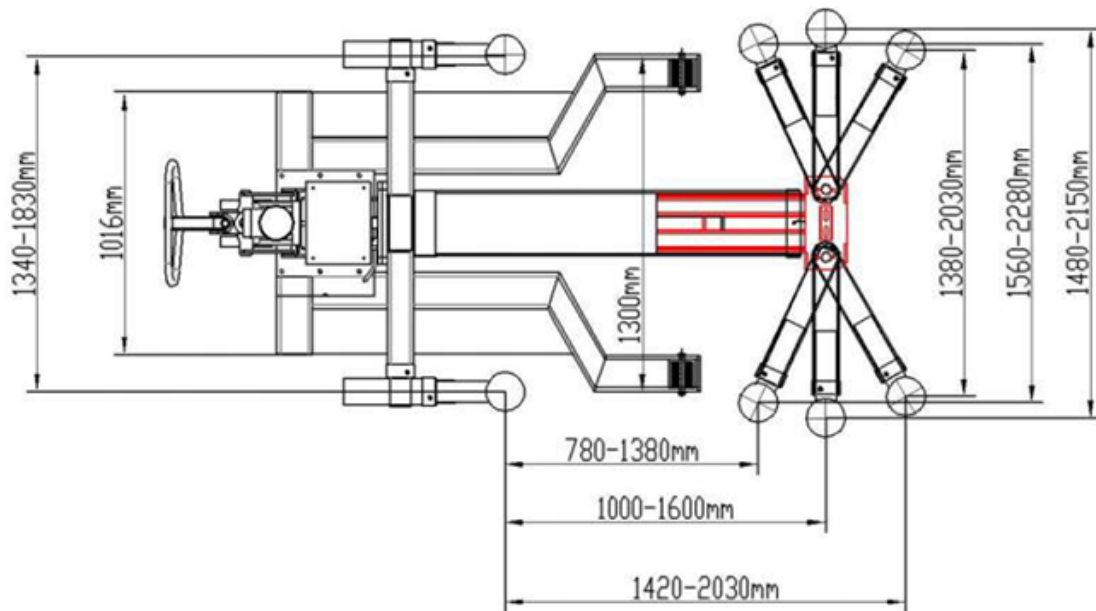
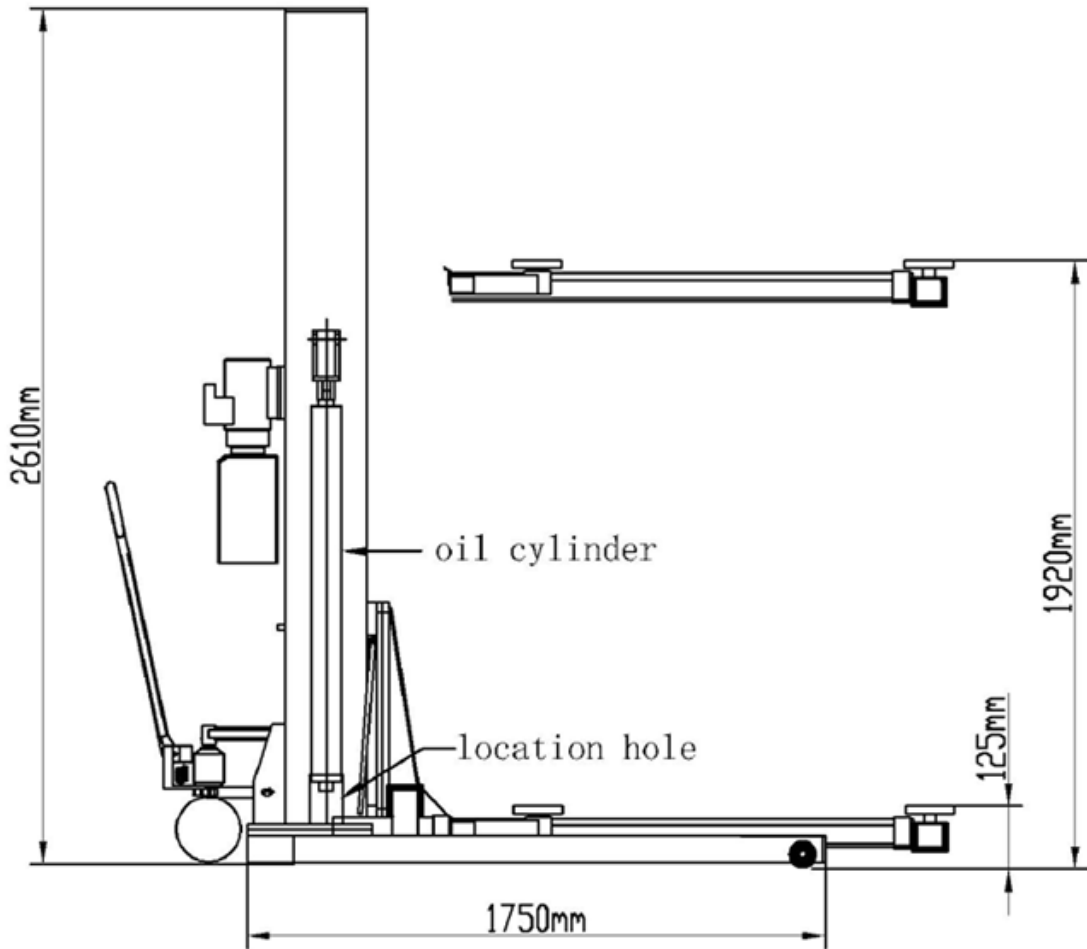

Hero Hoists QLD  
Address: 1/56 Commerce Circuit, Yatala QLD 4207  
M: 0432 761 705 | P: 07 3272 2952 | F: 07 5609 6031 | E: grant@herohoistsqld.com.au